



Lexmark CS517de



CS517de

Print more pages per month. In PANTONE® accurate color.

Some months are busier than others, but the CS517de can handle them. It's recommended for printing up to 7,000 pages per month at speeds up to 32 pages per minute. Each page features professional-quality color with proven PANTONE® color accuracy. Also offers advanced security, Gigabit networking, 4.3-inch color touch screen, keypad, 2-sided printing, available High Yield cartridges and mobile print capability.*

Amazing color, fast

Color matching tools and PANTONE® calibration make it easy to get consistent, accurate color output so you can save time and money by creating color documents in-house. Thanks to a dual-core processor and 512MB of memory (expandable up to 2.5GB), even documents with graphics and images print quickly. The CS517de can deliver the first color page in as little as 10 seconds.



Color



Network



Duplex



Unison Toner



Up to 32 ppm



Security



Mobility



4.3-inch touch screen

Security. Confidential Print. Mobile print capability.

Extensive network security features and protocols protect your device, information and network from unauthorized access. Keep your sensitive documents safe by enabling the Confidential Print feature, which requires entering a customized, unique PIN on the device's keypad before the document can be printed.

In addition, you can print from mobile devices using Lexmark's free Mobile Print app or an optional Wi-Fi adapter.

Comprehensive warranty

The CS517de color printer is so well made, we back it with a solid 1-year warranty that offers you multiple ways to obtain help: phone, email, live chat and remote assistance. Plus, if your device ever fails, we'll ship you a replacement device through our Advanced Exchange program so you're up and printing again as quickly as possible. See Statement of Limited Warranty for details.

* Requires free Lexmark Mobile Print app with Android or iOS mobile device

High Yield cartridges offer lower cost per page

Available High Yield cartridges deliver up to 3,500 color and 8,000 black pages. They never require shaking, which minimizes interruptions and keeps work moving. The Lexmark print system and Unison™ Toner ensure consistent print quality throughout the life of the cartridge to prevent wasted prints.

User-friendly

The CS517de is simple to install, easy to use and offers built-in networking and full compatibility with nearly every operating system and network, so you'll be up and running in minutes.

It's built to last, so you'll easily be able to print up to 7,000 pages per month with little maintenance, thanks to our state-of-the-art paper handling technology and long-life consumables.

Lexmark's Mobile Print app for iOS and Android devices provides a simple and consistent user experience for printing from mobile devices. It features simple printer discovery and mobile print.

Eco-friendly

Built-in two-sided printing reduces paper use. The instant warm-up fuser saves energy and delivers the first color page in as little as 10 seconds. Select an energy-saving mode (Quiet, Hibernate or Eco) to automatically minimize noise and energy consumption.

Through LCCP, the Lexmark Cartridge Collection Program, Lexmark offers a free and easy way for you to return your empty cartridges for sustainable recycling or remanufacturing.



Product specifications		Lexmark CS517de
Printing		
Display	Lexmark e-Task 4.3-inch (10.9 cm) color touch screen	
Print Speed: Up to ⁵	Black: 32 ppm / Color: 32 ppm	
Time to First Page: As fast as	Black: 9 seconds / Color: 10 seconds	
Print Resolution	Black: 4800 Color Quality (2400 x 600 dpi), 1200 x 1200 dpi / Color: 4800 Color Quality (2400 x 600 dpi), 1200 x 1200 dpi	
Memory / Processor	Standard: 512 MB / Maximum: 2560 MB / Dual Core, 800 MHz	
Hard Disk	Option available	
Recommended Monthly Page Volume ²	1500 - 7000 pages	
Maximum Monthly Duty Cycle: Up to ³	85000 pages per month	
Supplies⁷		
Laser Cartridge Yields (up to) ¹	3,500-page Colour (CMY) High Yield Cartridges, 3,000-page Black Cartridge, 2,300-page Colour (CMY) Cartridges, 8,000-page Black High Yield Cartridge	
Photoconductor Estimated Yield: Up to ⁶	40,000 pages, based on 3 average letter/A4-size pages per print job and ~ 5% coverage	
Cartridge(s) Shipping with Product ¹	4,000-page Color (CMY) Extra High Yield Return Program Toner Cartridges, 6,000-page Black starter Return Program Toner Cartridge	
Paper Handling		
Included Paper Handling	Single-Sheet Manual Feed, Integrated Duplex, 125-Sheet Output Bin, 250-Sheet Input	
Optional Paper Handling	550-Sheet Duo Tray with 100-Sheet Feeder, 550-Sheet Tray	
Paper Input Capacity: Up to	Standard: 250+1 pages 20 lb or 75 gsm bond / Maximum: 1450+1 pages 20 lb or 75 gsm bond	
Paper Output Capacity: Up to	Standard: 125 pages 20 lb or 75 gsm bond / Maximum: 125 pages 20 lb or 75 gsm bond	
Media Types Supported	Refer to the Card Stock & Label Guide., Transparencies, Plain Paper, Paper Labels, Card Stock	
Media Sizes Supported	Oficio, Universal, Letter, Legal, JIS-B5, Folio, Executive, A5, A4	
General Information⁴		
Standard Ports	Rear USB 2.0 Specification Hi-Speed Certified Port (Type A), Front USB 2.0 Specification Hi-Speed Certified port (Type A), Gigabit Ethernet (10/100/1000), USB 2.0 Specification Hi-Speed Certified (Type B)	
Optional Network Ports	MarkNet N8352 802.11b/g/n Wireless	
Noise Level: Operating	Print: 50 dBA	
Specified Operating Environment	Altitude: 0 - 2896 Meters (9,500 Feet), Humidity: 8 to 80% Relative Humidity, Temperature: 16 to 32°C (60 to 90°F)	
Limited Warranty - See Statement of Limited Warranty	1-Year Exchange, Onsite Service, Next Business Day	
Size (in. - H x W x D) / Weight (lb.)	12.1 x 17.4 x 16.0 in. / 46.1 lb.	

¹Average continuous black or continuous composite CMY declared cartridge yield up to this number of standard pages in accordance with ISO/IEC 19798. ²Recommended Monthly Page Volume² is a range of pages that helps customers evaluate Lexmark's product offerings based on the average number of pages customers plan to print on the device each month. Lexmark recommends that the number of pages per month be within the stated range for optimum device performance, based on factors including: supplies replacement intervals, paper loading intervals, speed, and typical customer usage. ³Maximum Monthly Duty Cycle³ is defined as the maximum number of pages a device could deliver in a month using a multishift operation. This metric provides a comparison of robustness in relation to other Lexmark printers and MFPs. ⁴Printers are sold subject to certain license/agreement conditions. See www.lexmark.com/printerlicense for details. ⁵Print and copy speeds measured in accordance with ISO/IEC 24734 and ISO/IEC 24735 respectively (ESAT). For more information see: www.lexmark.com/ISOspeeds. ⁶Actual Yield may vary based on other factors such as device speed, paper size and feed orientation, toner coverage, tray source, percentage of black-only printing and average print job complexity. ⁷Product functions only with replacement cartridges designed for use in a specific geographical region. See www.lexmark.com/regions for more details.

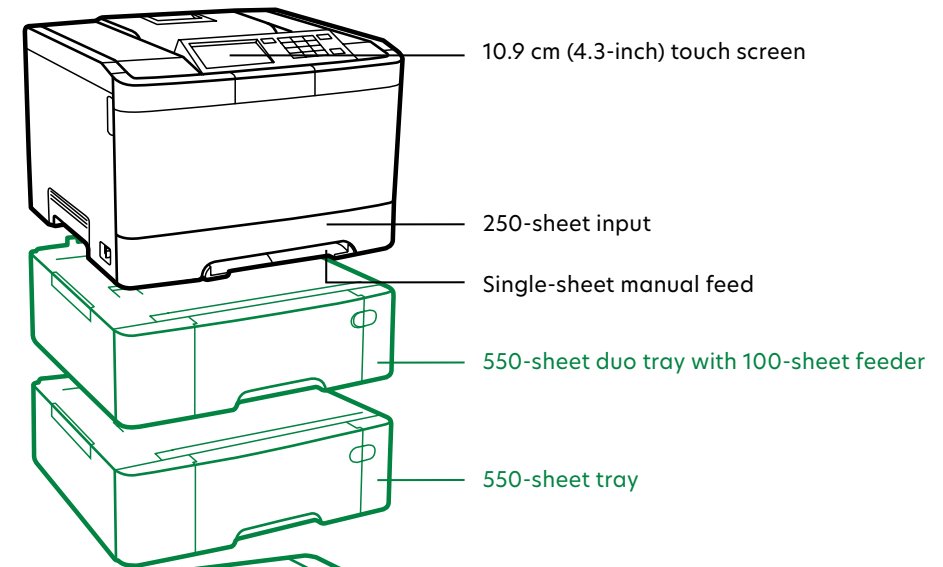

■ Standard
■ Optional

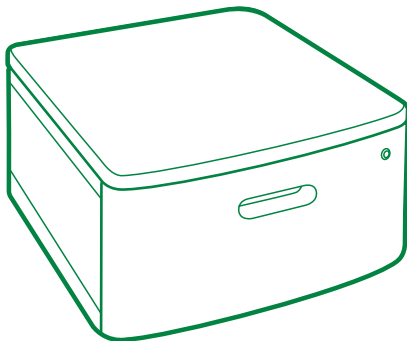

Swivel cabinet

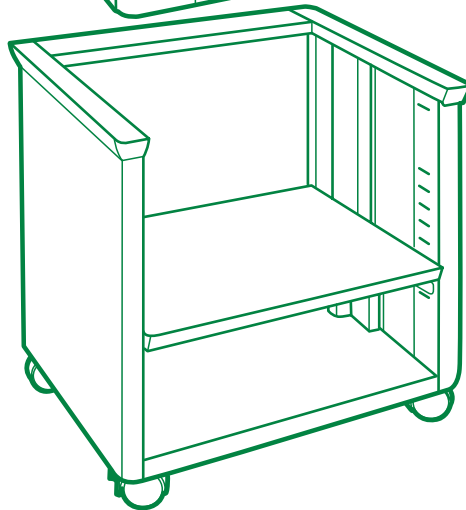

Adjustable printer stand